

MHP13AT/14AT

TRAILER MOUNTED BOOM LIFTS



- Safe and stable working height of up to 13.5m
- Heavy duty trailer mounted articulated boom lift
- Robust steel platform with two man capacity
- Easy to use outrigger/boom safety interlocks
- Ideal for a wide range of applications

 **snorkel**[™]
www.snorkellifts.com

TRAILER MOUNTED BOOM LIFTS

MHP13AT/14AT

DIMENSIONS	MHP13AT	MHP14AT
Max.height	12.9m	13.5m
Max. platform height (A)	10.9m	11.5m
Horizontal outreach	6.4m	6.4m
Platform size	1.15m x 0.7m	1.15m x 0.7m
Overall width (outriggers extended)	3.6m	3.6m
Overall width (outriggers retracted) (B)	1.6m	1.6m
Overall length (C)	4.9m	4.9m
Transport length (D)	2.0m	2.0m

PERFORMANCE	MHP13AT	MHP14AT
Platform capacity	215kg	215kg
Max. wind speed	12.5m/s	12.5m/s
Levelling	auto	auto
Turntable rotation	540° non-continuous	540° non-continuous
Tyres	185 R14 102/100P	185 R14 102/100P
Brakes	Hydraulic over-run non free reversing	
Insulation rating	Nil	Nil
Trailer tongue weight	80kg	80kg

POWER	MHP13AT	MHP14AT
Power source	Honda petrol	Honda petrol

WEIGHT	MHP13AT	MHP14AT
Gross weight	1,460kg	1,460kg

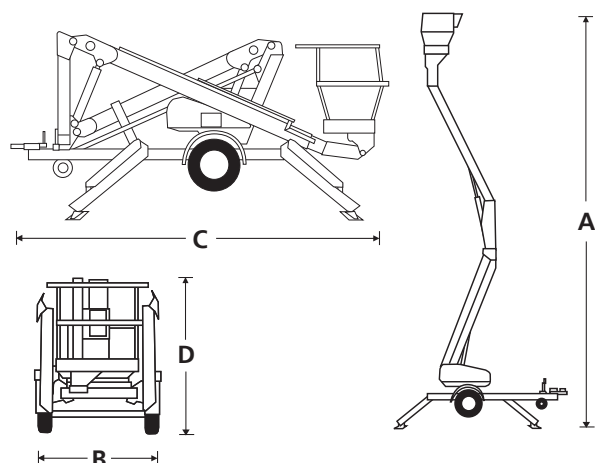

STANDARD FEATURES

- Heavy duty tow coupling
- Hydraulic stabilisers
- Two man steel platform
- Two person capacity
- Heavy duty jockey wheel
- Hydraulic disc brakes
- Reliable petrol engine
- Outrigger boom safety interlocks
- Platform foot switch
- Spare wheel
- LED taillights
- Lifting lugs
- Automatic stabilisers
- Rotating basket mount
- Basket overload

OPTIONS

- Custom colours
- Platform work lights
- Air line to platform
- Flashing light
- Height lockout (MHP14AT only)
- 240V 110V outlet in platform
- Battery isolate switch
- Diesel and bi-energy options

WORKING ENVELOPE

