

SR626E

ELECTRIC COMPACT ROUGH TERRAIN TELEHANDLER



- Zero emission electric compact rough terrain telehandler with lithium-ion batteries
- Full-time 4 wheel drive
- Fully enclosed cab
- Power assisted steering
- Proportional joystick
- Simple to operate & maintain



snorkel[™]
www.snorkellifts.com

ELECTRIC COMPACT ROUGH TERRAIN TELEHANDLER

SR626E

CAPABILITIES SR5719*

Max. lift capacity	2,600kg
Max. lift height (A)	5.79m
Max. forward reach	3.1m

DIMENSIONS

Overall width (B)	1.89m
Stowed height (C)	1.93m
Length to fork face (D)**	4.19m
Wheelbase	2.5m
Ground clearance	220mm

PERFORMANCE

Max. drive speed	12km/h
Raise/lower time	6.9/5 sec
Hydraulic flow (per minute)	80L
Hydraulic pressure	230bar
Hydraulic oil capacity	70L
Outside turning radius	3.25m
Tyres	12 x 16.5

POWER

Power source	Lithium-ion 80V 32kWh batteries
Operating temperature	(-)20°C to (+)45°C
Charger	on-board, single phase

WEIGHT

Weight	4,800kg
--------	---------

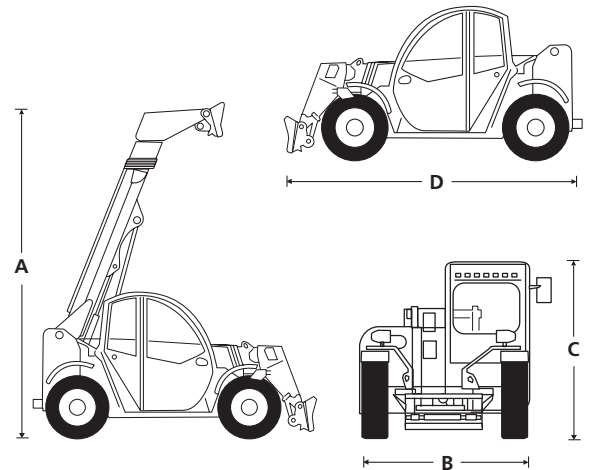

STANDARD FEATURES

- Lithium-ion batteries
- Full time 4 wheel drive
- 4 wheel steer
- Selectable front, crab & coordinated steering modes
- Auxiliary hydraulic circuit on the boom
- Variable speed hydrostatic drive
- Fully enclosed cab
- Proportional joystick
- Adjustable steering column
- Illuminated gauge and switch panels
- Color LCD display with machine & engine diagnostics
- Adjustable suspension seat
- Flashing beacon
- Fixed 1.2m carriage
- 1.2m pallet forks
- 2000 charging cycles/2 year *** lithium battery warranty
- 2 year parts & labour, 5 year structural warranty
- CE approved

OPTIONS

- Special paint colours
- Multiple options for carriages, tyres and fork tines
- LED front and rear work lights (4)
- LED work lights on boom (2)
- External three-phase fast charger

LOAD CHART

