

# ML5I/ML10I/ML15I

## MATERIAL LIFTS



- A high specification material lift with heavy-duty load capacity
- Narrow design to manoeuvre through a standard doorway without tilting back
- Robust, industrial grade design
- Features a dual handle, shift- on-the-fly, two-speed winch for improved productivity

 **snorkel**  
[www.snorkellifts.com](http://www.snorkellifts.com)

DIMENSIONS	ML5I	ML10I	ML15I
Lift height – forks up	2.0m	3.4m	4.8m
Lift height – forks down	1.4m	2.7m	4.3m
Stowed width (A)	0.77m	0.77m	0.77m
Stabiliser width (B)	1.63m	1.63m	1.63m
Stowed length	0.85m	0.85m	0.85m
Operating length (C)	1.57m	1.57m	1.70m
Stowed height (D)	1.9m	1.9m	1.9m
Fork width (outside)	0.58m	0.58m	0.58m
Fork length (E)	0.76m	0.76m	0.76m
Ground clearance	60mm	60mm	60mm

PERFORMANCE	ML5I	ML10I	ML15I
Max. load capacity (0.36m load centre)	454kg	408kg	363kg
Max. load capacity (0.61m load centre)	340kg	340kg	318kg
Max. load capacity (1.07m load centre)	159kg	159kg	147kg
Min. load height	150mm	150mm	150mm
Winch (high speed)		13.1 cranks/m	
Winch (low speed)		49.2 cranks/m	

WEIGHT	ML5I	ML10I	ML15I
Weight	89kg	106kg	122kg

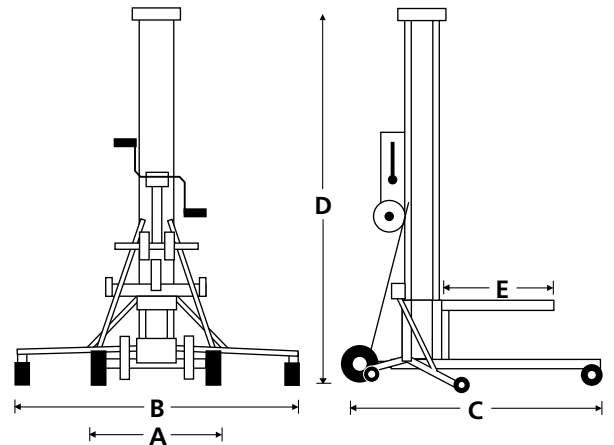

## STANDARD FEATURES

- Mast brake
- Cable guard
- Non-marking transport/loading wheels
- Dual handle, two-speed shift-on-the-fly winch
- Metal cable pulleys with sealed bearings
- Heavy-gauge aluminium extrusions
- Heavy-duty, non-marking casters
- Quick-fold stabilisers
- Crane attachment point
- 2 year parts & labour, 5 year structural warranty
- CE Approved

## OPTIONS

- Special paint colours
- Adjustable forks
- Boom
- Pipe cradle
- Fork extensions
- Load platform
- Stabilisers with non-marking swivel casters
- Straddle base

## LOAD CAPACITY - STANDARD FORKS

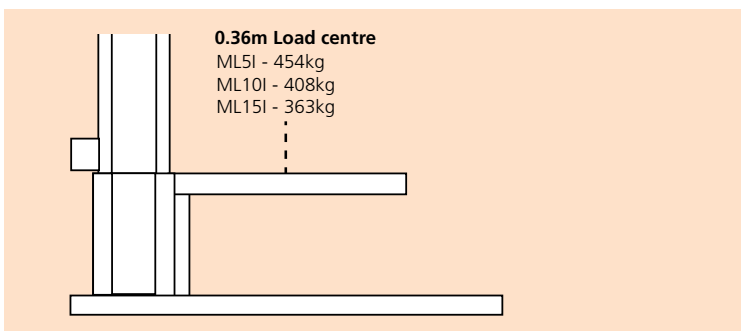

## LOAD CAPACITY - EXTENDED FORKS

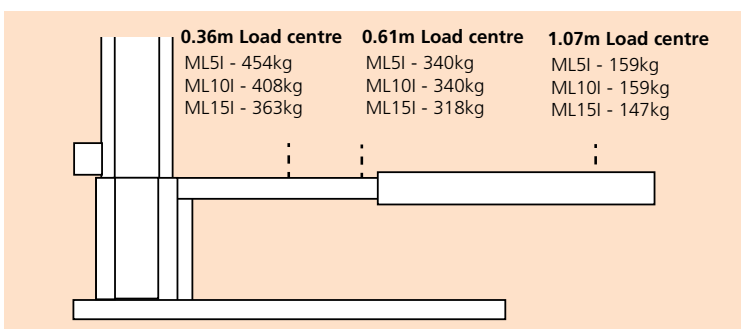

**snorkel** [www.snorkellifts.com](http://www.snorkellifts.com)

Vigo Centre, Birtley Road,  
 Washington, Tyne & Wear,  
 NE38 9DA, U.K.

t: +44 (0) 845 1550 057  
 e: sales.emea@snorkellifts.com